

# **Michiana Division**



National Model Railroad Association  
Midwest Region

## **FORM - 19**

Model Railroading in the Digital Age



## A publication of the NMRA, Midwest Region, Michiana Division

Model Railroading in the Digital Age is the slogan of the Newsletter.

In keeping with this line we will feature digital information depicting aspects of digital modeling.

### 1ST QUARTER DIVISION EVENT SCHEDULE

**SATURDAY, January 14**  
**10AM CT, 11AM ET**  
**ZOOM**  
**MEETING**  
**TBD**

**SATURDAY, February 11**  
**10AM CT, 11AM ET**  
**ZOOM**  
**MEETING**  
**TBD**

**SATURDAY, March 11**  
**10AMCT, 11AM ET**  
**TBD**

**PLEASE,  
STAY SAFE  
AND HEALTHY**



### January 2023 Form-19 Superintendent's Message By Greg Bueltmann HAPPY NEW YEAR 2023

Greetings Model Railroaders!

**NOTICE: Starting in January 2023 the Michiana Division will change our regular Saturday meeting to the second Saturday of the month.**

It was great for Division members to meet in person this fall. In October we visited the NYC museum in Elkhart, IN to see some additional attractions that have added to the museum.

Also in October, there was a nice turn out in Michigan City, IN for the South Shore Shops tour given by Greg Yovich, where we learned about the forth-coming upgrades to their passenger cars.

November is traditionally Model Railroad Month. We met at the New Carlisle, IN library. Ron Christensen MMR, presented a power point clinic about the AP program with Chief Dispatcher as the subject. The division has been using the November meet to highlight the AP program and plans to continue this format in the future.

In December not knowing what the weather may be we went back to a ZOOM meeting. I gave a presentation on my layout telling about the research and build of the Niagara paper mill.

Election time is coming up this spring. The Division is looking for candidates for Superintendent and 3 Board of Director positions. The Division is also looking to fill the Chief Clerk and Membership Chairman positions. Please consider giving the Division your attention and remember these positions count toward points for the Volunteer AP Certificate.

## Welcome to the 1ST Quarter of the FORM-19 for 2023

**Invitation:** Please join us in our meetings for fellowship and learning with other model railroad enthusiasts. We meet on the 2nd Saturday, almost every month. See the location, time and topic at <http://michiana-nmra.org/meetings.html> as well as topics from previous meetings. The **next regular meeting is January 14, 2023.**

**Future meetings & ideas for topics:** Future meetings for the Division would like to alternate locations between eastern and western areas of the Division, attracting more members from west of La Porte. Also, we may be able to “Zoom” some meetings in the future for those who cannot attend in person. We invite you to suggest topics interesting to you. You can do this by posting your ideas on the Division’s **groups.io**. Meeting locations and other attractions are mapped at <http://www.michiana-nmra.org> just click on “Resources” “Michiana Division Interactive Map”.

## ROAD TRIPS?

Train shows are continuing to come back and so are in-person conventions. So lets look at the possibilities of hitting the road over the next few months. We’ll look at both model and prototype getaways available and the opportunities to get together with old friends we may not have seen for a while and meet some new friends. Don’t forget to take your models and photos to display and/or enter into the contest rooms when attending a Region and National Convention.

## MICHIANA DIVISION ROAD TRIP IDEAS

### SWAP MEETS AND TRAIN SHOWS

Here is a source for train shows and swap meets that may be in the primary area of the Michiana Division.

For the five state area of Wisconsin, Illinois, Indiana, Michigan and Ohio.

<https://www.trainshowlist.com>

### **MICHICANA DIVISION AREA SWAP MEETS February and March**

February 26, 2023 Michigan City Swap Meet,  
La Porte County Fairgrounds Community Building  
9:30am – 2:00pm CT 2581 IN-2, La Porte, IN

March 18, 2023 18<sup>th</sup> Elkhart Model RR Club Swap Meet,  
Claywood Event Center  
10:00am – 3:00pm ET 13924 N 1100 W (County Line RD), Nappanee, IN  
Elkhart Train Show information is on the web at [www.emrrc.com](http://www.emrrc.com)

## **LAYOUT ELECTRONICS PROJECT**

### **Engine Facility Track Power Control**

#### **By Chuck Hart**

DCC is great as you always have power applied to the tracks. However, in some areas of the layout it may be desirable to turn off track power until it is needed. One key area may be an engine facility that has a large number of locomotives continuously drawing power from a command station or booster.

There are a couple methods to control individual track power on and off, which include toggle and rotary switches. If you are only controlling a switcher pocket or just a couple tracks for a small engine house then a SPST toggle switch is probably the easiest method. When the area to control is a large engine facility then a rotary switch may be the answer. This may also apply to a staging area that has a large number of tracks.

The diesel engine facility on my Pacific Central and Eastern Railroad has 9 facility tracks. There may be up to 15 to 20 locomotives in the facility at any time. I decided to control these tracks with the addition of a rotary switch. I also wanted to add a few embellishments to the facility track power control. Here is the list of minimum requirements.

- Select a specific track
- Indicate when the controller is sending power to the track
- Automatically kill track power after a specified period of time
- Indicate when the controller is not sending power to the track
- Possible kit to satisfy most of the required circuitry

To satisfy the requirements I knew I would need a rotary switch, a timer circuit, a relay, a couple of push buttons, a couple of LEDs and a separate power supply for this circuit. (The search was on.) There are many timer circuit schematics available on the Internet and the electronic parts are available from many sources. Too bad Radio Shack is no longer available in most areas now. (The RS store near me in Niles, MI is still in business.) I didn't want to have to make a printed circuit card and obtain all the parts from different sources so I started to look for 'Timer Circuit Kits'. There lots of these available in various configurations and functions. Just Google 'timer circuit kits'. I found what I wanted as a starter circuit for my project from All Electronics. <https://www.allelectronics.com> All Electronics carries thousands of electronics parts, tools, and educational and other projects kits. I chose a VELLEMAN-mini kit MK111 as a starter for this project. This kit uses a 555 Timer chip. Basic starter kits are available from many sources. While this kit does not do exactly what I wanted, it was easy to make a few modifications to the circuit, a couple of cuts to the PC Board and a couple added components to accomplish my requirements. I also eliminated a couple parts in the kit that were not needed for the project.

## Engine Facility Track Power Control, Cont.

Additional parts required for this project included:

- Wall Wart 12VDC, 1 amp power supply
- Green LED for track power 'ON' indicator
- Red LED for track power 'OFF' indicator
- Some hookup wire
- A resistor not included in the kit
- SPST push button switch to apply track power to 'ON'
- SPST push button switch to RESET the timer to 'OFF' if required
- Rotary switch

### OPERATION:

- Select the desired track with the rotary switch
- Push the 'ON' Button. Green LED is illuminated.
  - The 'ON' push button starts the 555 Timer circuit and energizes a relay applying track power to the selected track via the rotary switch. A variable resistor on the circuit board controls the track power 555 Timer sequence.
- After the 'ON' period setting times out by the 555 timer circuit the track power automatically turns off.
- When track power is off the Red LED is illuminated.
- The 'RESET' push button can be used to reset the 555 Timer to turn off early
  - This can also be used in case the engine facility hostler has selected the wrong track and will not have to wait for the 555 Timer to time out.

Notes: My controller is set to keep a selected track powered on for about 40 seconds. This has proved to be plenty of time for a locomotive to be moved in or out of a facility track before the timer automatically turns off. This solution also keeps track power off until it is needed and the operator does not have to remember to turn the power off after use. If more time is needed to control a locomotive then the 'ON' button just needs to be pressed again to allow for additional locomotive movement time.



**LEFT: VELLMANN 555 Timer Kit used for this project. The kit was modified to perform the functions needed for the Engine Facility Track Power control. Similar kits are available from many sources.**

**RIGHT: I used a 1 pole, 12 position rotary switch. The shaft is cut to length after installation and a standard knob fits the 1/4" switch shaft.**



Engine Facility Track Power Control, Cont.

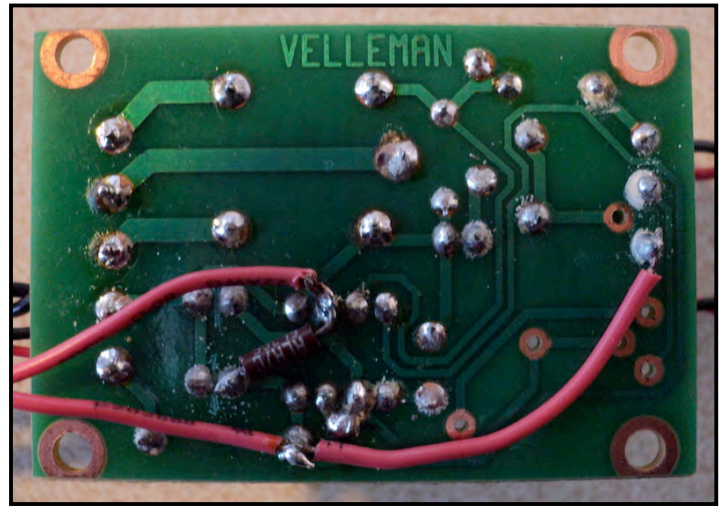
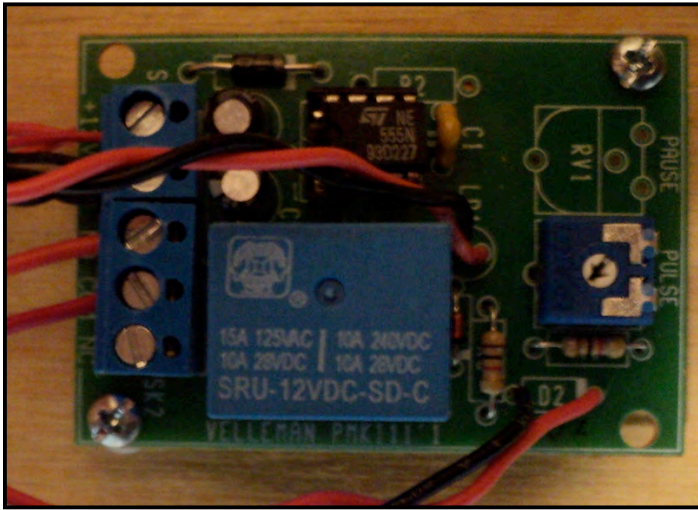

**ABOVE:** Component side and circuit trace side showing the modifications made for this project. Notice some parts were not needed and an additional resistor was added to the circuit.

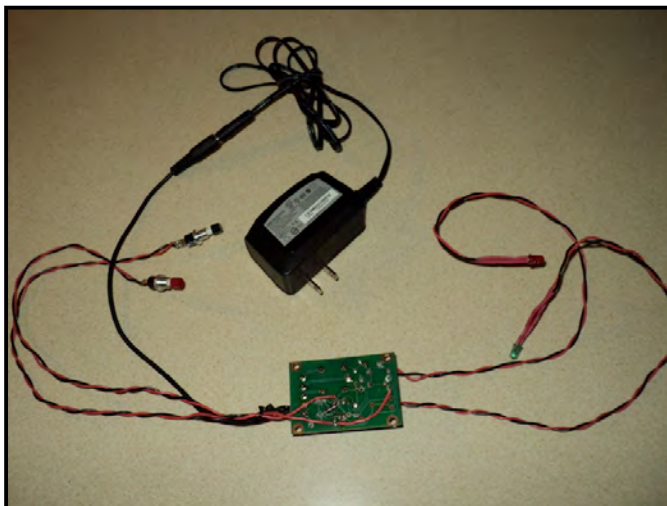

**LEFT:** Here are the components wired to the circuit board and ready for installation. This includes the Wall Wart power supply, the push buttons and the LEDs.

After installation the Rotary switch common and the 'A' track power feed is connected to the circuit card connector. (See the bottom two red wires in the left photo above)

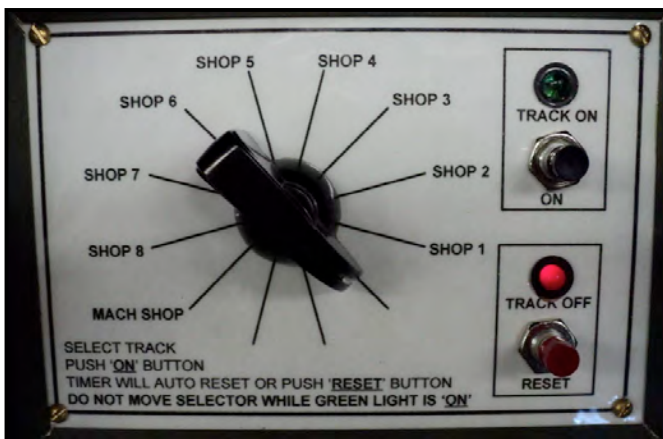

**ABOVE:** The control panel in the idle mode and ready for use.

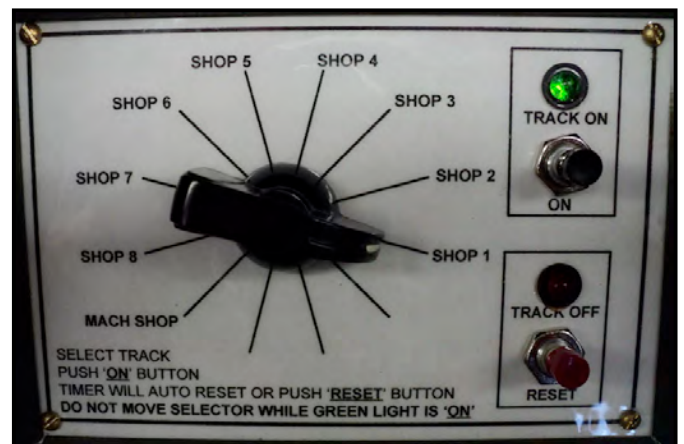

**ABOVE:** The control in operation mode for SHOP 1 track. After about 40 seconds of time the controller will automatically turn off and kill the power to the track.

Engine Facility Track Power Control, Cont.



**ABOVE: The engine facility has 9 tracks (one track leading to the RIP/MACHINE SHOP is out of view in the upper left).**

**BELOW: The Engine Facility Track Power Control mounted in the fascia.**



Engine Facility Track Power Control, Cont.

**SIMPIFIED WIRING DIAGRAM**

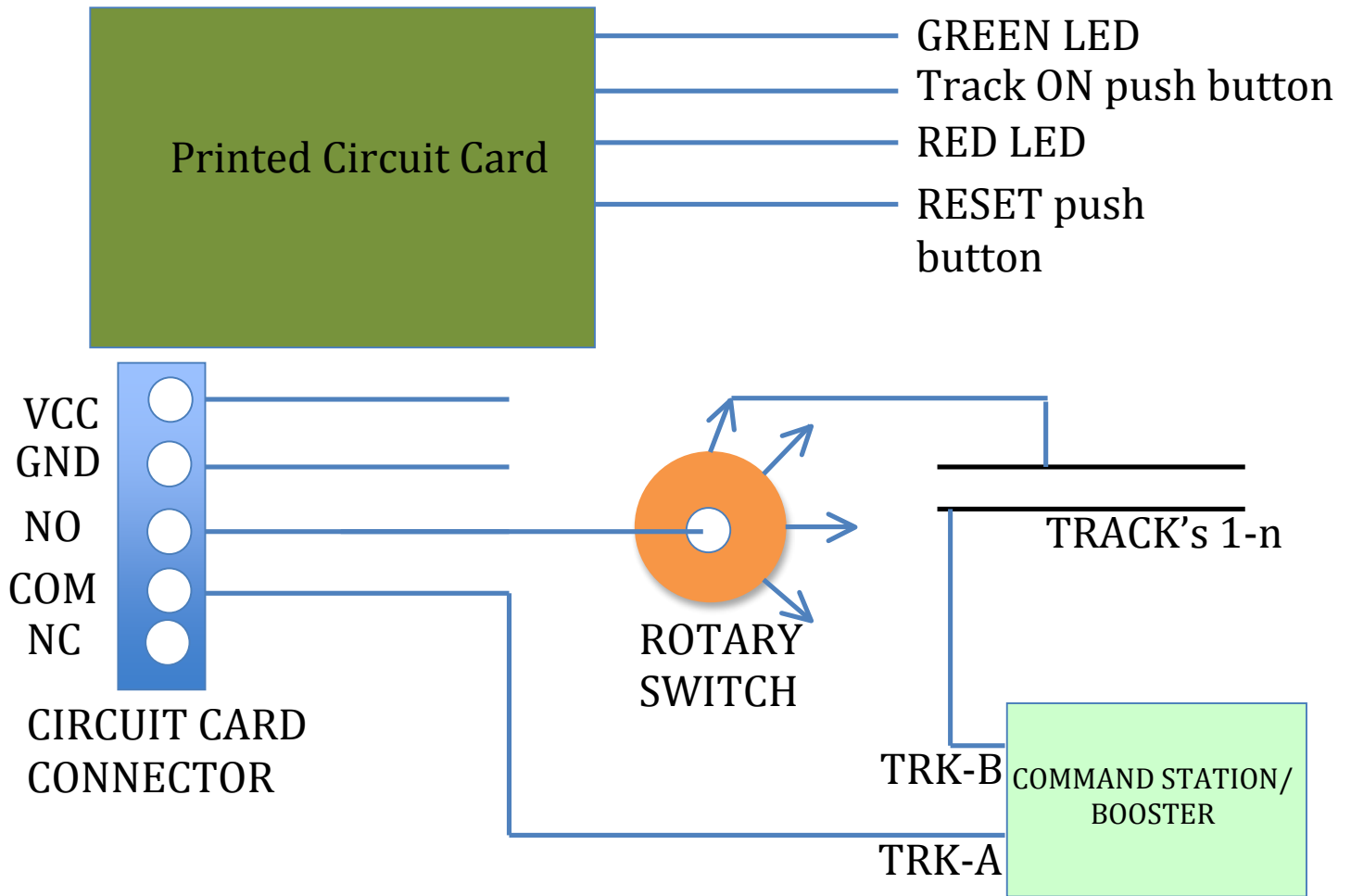

When the TRACK ON button is pushed the relay on the circuit card will be energized and will switch to the normally open (NO) position and apply the Track A power to the track selected by the rotary switch. After the time out of the 555-timer circuit the relay will de-energize and rest back to the normally closed (NC) position and release the power to the track.

## John Nye's Great Northern, Santa Fe and Union Pacific December 2022 Operations Session

*Article by Chuck Hart / Photos by Ron Jillson*

Michiana Division member, John Nye, has a big layout in a large building with beautiful mountain scenes and large cities with many industries. John already has a couple of dedicated people working on the layout building structures and applying scenery material. About 2 years ago John expressed an interest in developing operating sessions for his empire. Taking up the challenge, many Division members have pitched in to help document John's railroad, train routes have been diagrammed, industries have been identified and changes to the railroad's configuration are being made where needed. This process is still on going. While the railroad is going through some changes Division members are creating documentation for operations. The railroad's story and history is in process, car cards have been developed; train routes have been created with train numbers and industry-switching moves are being identified. A tentative Operations Plan has been developed and published and it is now able to support early operation sessions. With the help of a dedicated group of Division members and in very short period of time, John's railroad is now productive delivering passengers to their destinations and freight trains are picking up and dropping off goods to the industries. Below are a few pictures from the December 2022 operations session with a few of these dedicated people experiencing the fruits of their labor from over the last two years of weekly work sessions. The process continues....



**ABOVE: Left to right. Dan Cress is keeping a watchful eye on his train as he backs into the tank farm. Other operators are Dan Brewer, Allen Black and Sparky Byers.**



**John Nye December 2022 Operations Sessions, cont.**



**LEFT: Ron Christensen MMR, is in charge of the Hump Yard while Fred Ochs, Bob Blake, Dan Brewer and Duane Henry with Allen Black in the rear of the photo are busy operating their trains**



**RIGHT: Michiana Division Superintendent, Greg Buelmann enjoying the OPS Session**

**BELOW: Michiana Division Paymaster, Jim Temple is looking over his train instruction card with Duane Henry, Dan Brewer and Bob Blake in the rear of the photo**



## Thursday Evening Zoom Meets

Join us on **Thursday** evenings at 6:30 central / 7:30 eastern. These Thursday Model Railroad Zoom calls started in May 2020 with a small group and have grown to include many devoted model railroaders from all over the country. The topics are as varied as the people who present. The invite is sent every week to the NMRA Michiana Division groups.io mailing list. If you are not receiving the invites, please contact GREG BUELTMANN, email [greg@uncleheavy.com](mailto:greg@uncleheavy.com).

## Call for Candidates

### MICHINANA DIVISION ELECTIONS FOR 2023

#### From the Nominations Committee

1. *Michiana Division Board Of Directors Elections* will be held during the 2023 Annual Membership Meeting in May 2023. There are three openings for the Michiana Division Board of Directors. The Nominating Committee is soliciting for candidates at this time. This is a two-year term position. If you are a current paid-up member of NMRA MWR Michiana Division in good standing and are interested in serving as a Board Member, please submit your name before April 30, 2023 to the Nominating Committee Chairman: James Temple, email: [jngtemple@yahoo.com](mailto:jngtemple@yahoo.com)

2. *Michiana Division Superintendent Election* will be held during the 2023 Annual Membership Meeting in May 2023. The Nominating Committee is soliciting for candidates at this time. This is a two-year term position. If you are a current paid-up member of NMRA MWR Michiana Division in good standing and are interested in serving as the Michiana Division Superintendent please submit your name before April 30, 2023 to the Nominating Committee Chairman: James Temple, email [jngtemple@yahoo.com](mailto:jngtemple@yahoo.com)



# NMRA NEWS

## **NMRA Digital Magazine - Arrived at the Station on April 1<sup>st</sup>!**

We hope you are all are trying out and enjoying the launch of the NMRA Digital Magazine as much as we are. So far, we have provided the basic information in terms of dues, availability and general benefits.

On mobile devices, laptops, and desktops, the magazines are available as full pages as if reading the print version, as well as a special flowable text version. The flowable text makes it easier to read individual articles by enlarging the text and placing it into one continuous column for easy scrolling. It is simple to go back and forth between the versions.

The digital NMRA Magazine is searchable by keywords so it is easy to find your favorite railroad or topic. You can also bookmark articles for quick access later.

Members are able to save issues offline for viewing when Internet access is not available. This means you can access current and back issues of the NMRA Magazine anytime and anywhere.

## **Are you taking advantage of the NMRA Partnership Program?**

The NMRA has partnered with model railroad manufacturers of all sizes who have agreed to give discounts to NMRA members. Discounts range from free shipping to 40% off all purchases. From Micro-Mark to Rusty Stumps, more manufacturers are being added every month. To see the current listing, log in to our website and visit the Partnership page in the Members Only section: [www.nmra.org](http://www.nmra.org) Membership, Member Home, Benefits, NMRA **Partnership Program**. **There are now more than 50 Partners participating in the program.**

### **It just became easier to purchase stuff from the NMRA**

**The NMRA now accepts**



- **Renewals**
- **Memberships**
- **Books**
- **Donations**
- **Online store**
- **EVERYTHING**



**National Model Railroad Association, Inc.**  
**New Member Application**

<b>Name:</b>		
<b>Address:</b>		
<b>City:</b>	<b>State/Country</b>	<b>Zip:</b>
<b>Phone:</b>	<b>Birth Date:</b>	<b>Scale:</b>
<b>Email:</b>	<b>Occupation:</b>	

Membership	1 Year	2 Year	Total
Member - All rights & benefits as well as the digital NMRA magazine access.	\$68.00	\$136.00	
Member with Printed Magazine Subscription – All rights & benefits, digital NMRA Magazine access and the Printed Magazine.	\$92.00	\$184.00	
Family – Spouse or minor child of above member. No magazine, no voting rights, not allowed to hold office.	\$10.00	\$20.00	
Sustaining – Mandatory for group memberships (Clubs, Business, Associations). All rights & benefits, digital NMRA Magazine access and the Printed NMRA magazine.	\$120.00	\$240.00	
Student – Between the ages of 19-25 years of age. All rights & benefits, digital NMRA magazine access.	\$40.00	\$80.00	
<b>Membership</b>			\$
<b>General Donation</b>			\$
<b>Merchandise</b>			\$
<b>Region Subscription</b>			\$
<b>Total</b>			\$

**Thank you for being a member of the NMRA! It is extremely important to have your current email address on file. This is used for access to the member only section, turntable, ballots, voting, annual donation statements, online renewals and communication. Please be sure to note your email address below.**

Email:

Region Subscriptions			
<b>If you do not see your region listed, there is no charge for region subscription! Most regions offer the subscription online on the website.</b>			
21 Northeastern Region	\$12.00	28 Midwest Region	\$6.00
23 North Central Region	\$10.00	33 Southeastern Region	\$10.00
26 Pacific Coast Region	\$8.00	36 Sunshine Region	\$12.00

**Make Checks Payable to NMRA. We accept MasterCard, Visa, Discover, and American Express.**

Credit Card Number:

Expire Date:    CVV Code:    Signature: \_\_\_\_\_

Mail To: NMRA, P. O. Box 1328, Soddy Daisy, TN 37384-1328  
 Email: [HQ@NMRA.ORG](mailto:HQ@NMRA.ORG)  
 423-892-2846

**Michiana Division YouTube Channel is now live!**

You can now view videos from our Division ZOOM meetings and other event videos. Check out our YouTube channel at

<https://www.youtube.com/channel/UCbvaWZMhVoRweILW3aiXZlQ>

**YOUR Michiana Division needs your help.**

Neal Thomas has left the MWR Michiana Division and has moved to the NCR. Neal has contributed to the Division as the Membership Chairman and in the role of Chief Clerk. It is desirable to split these rolls between two people. If you have experience with Microsoft products including MS Word and MS Excel please consider filling one of these positions. Only a few hours a month is required and would fill the up coming vacancies. Please contact Superintendent Greg Bueltmann.

**Michiana Division - 2815**

The Michiana Division was activated effective September 13, 2009.

Includes the following Counties in Indiana: Elkhart, Fulton, Jasper, Lake, La Porte, Marshall, Newton, Porter, Pulaski, Saint Joseph, and Starke and the following Counties in Michigan: Berrien and Cass.

**Michiana Division Committees**

AUDIT COMMITTEE	JIM TEMPLE
NOMINATING COMMITTEE	JIM TEMPLE
ELECTION COMMITTEE	JIM TEMPLE
MEMBERSHIP COMMITTEE	VACANT
CLINIC COMMITTEE	RON CHRISTENSEN, MMR
INTERNET COMMITTEE	GREG BUELTMANN
PUBLICATIONS COMMITTEE	CHUCK HART
CONVENTION COMMITTEE	VACANT
MEET LOCATION COMMITTEE	JOHN BANICKI
AP CHAIRMAN	RON CHRISTENSEN, MMR

We are always looking for help with organizing and making the division stronger from within the membership. Please consider taking the load off by volunteering a small amount of your time.

DIV. SUPERINTENDENT	GREG BUELTMANN	<a href="mailto:greg@uncleheavy.com">greg@uncleheavy.com</a>
CHIEF CLERK	VACANT	
PAYMASTER	JIM TEMPLE	<a href="mailto:jngtemple@yahoo.com">jngtemple@yahoo.com</a>
DIRECTOR-AT-LARGE	JOHN BANICKI	<a href="mailto:jjbmish@gmail.com">jjbmish@gmail.com</a>
DIRECTOR-AT-LARGE	RON CHRISTENSEN, MMR	<a href="mailto:rxensen@yahoo.com">rxensen@yahoo.com</a>
DIRECTOR-AT-LARGE	CHUCK HART	<a href="mailto:chart7968@yahoo.com">chart7968@yahoo.com</a>
DIRECTOR-AT-LARGE	VACANT	